

Actuator LA14

The actuator LA14 is a very tough actuator with a high IP degree and aluminium housing, making it ideal for use in harsh and demanding environments. The LA14 offers top quality in every detail and ensures reliable performance in temperatures ranging from -40° to +85 °C.

With its small size the LA14 is well suited for applications that require short linear movements.



Features:

- 12 or 24 V DC permanent magnetic motor
- Max. thrust 750 N
- Max. speed up to 45 mm/sec. depending on load and spindle pitch
- Stroke length from 19 to 130 mm
- Compact design, built-in dimensions 245 mm (up to 345 mm)
- Protection class: IP66 (dynamic) and IP69K (static)
- Built-in endstop switches
- Stainless steel inner tube and zinc coated steel piston rod eyes

Options in general:

- Exchangeable cables in different lengths up to 5 m
- Stainless steel piston rod eye
- Special anodised housing for extreme environments
- IECEx/ATEX certified for Zone 21
- Hall effect sensor
- Potentiometer - max. stroke length 100 mm
- IC options including:
 - IC - Integrated Controller
 - Integrated Parallel Controller
 - LIN bus communication
 - Analogue or digital feedback for precise positioning
 - Endstop signals
 - PC configuration tool

Usage:

- Duty cycle at 750N and 2mm pitch is max. 20%
- Duty cycle at 300N and 4mm pitch is max. 40%
- The duty cycles are valid for operation within an ambient temperature of +5°C to +40°C
- Ambient operating temperature: -40° to +85°C, full performance from +5°C to +40°C
- For IECEx/ATEX:
Ambient operating temperature: -25°C to +65°C



This TECHLINE[®] actuator comes with IC - Integrated controller.

For more information on our IC options, please see: www.linak.com/techline



WE IMPROVE YOUR LIFE

Chapter 1

Specifications 3

Technical specifications 4

Stroke tolerances 4

Built-in tolerances 4

LA14 Dimensions 5

LA14 Back fixture orientation 5

LA14 Piston Rod Eyes 6-9

Cable dimensions 10

Speed and current curves 11-12

Chapter 2

I/O specifications:

Actuator without feedback 13

Actuator with:

Endstop signals and relative positioning - Single Hall 14

Endstop signals and absolute positioning - Analogue feedback 15

Absolute positioning - Mechanical potentiometer feedback 16

Endstop signals and absolute positioning - PWM 17

IC Basic 18

IC Advanced - with BusLink 19-20

Parallel 21

IC options overview 22

Feedback configurations available for IC Basic, IC Advanced and Parallel 23

Actuator configurations available for IC Basic, IC Advanced and Parallel 24

Chapter 3

Environmental tests - Climatic 25-26

Environmental tests - Mechanical 26

Environmental tests - Electrical 27

Non-complying standards 27

Chapter 1

Specifications

Motor:	Permanent magnetic motor 12 or 24V DC
Cable:	Motor: 8 x 18 AWG PVC cable
Housing:	The housing is made of casted aluminium, coated for outdoor use and in harsh conditions
Spindle part:	Inner tube: Stainless steel AISI304/SS2333 Acme spindle: Trapezoidal spindle with high efficiency
Temperature range:	- 40° C to +85° C For IECEx/ATEX: - 25° C to +65° C - 40° F to +185° F - 13° F to +149° F Full performance +5° C to +40° C
Storage temperature:	-55° C to +105° C
Weather protection:	Rated IP66 for outdoor use. Furthermore, the actuator can be washed down with a high-pressure cleaner (IP69K)
Noise level:	With standard motor: 50-53dB (A) With fast motor: 58-63 dB (A) Measuring method DS/EN ISO 3743-1 actuator not loaded
Compatibility:	The LA14 IC is compatible with SMPS-T160 (For combination possibilities, please see the User Manual for SMPS-T160)

Be aware of the following two symbols throughout this product data sheet:



Recommendations

Failing to follow these instructions can result in the actuator suffering damage or being ruined.



Additional information

Usage tips or additional information that is important in connection with the use of the actuator.

Technical specifications

Type	Motor voltage (V)	Spindle Pitch (mm)	Thrust max. Push/Pull (N)	Self-lock max. (Push) (N)	Self-lock max. (Pull) (N)	*Typical speed (mm/s)		Stroke length (mm)			*Typical Amp. (A)	
						No load	Full load	Min.		Max.	No load	Full load
14020xxxxxxxxxA...	12	2	750	750	375	15	8	19	-	130	0.3	2.4
14020xxxxxxxxxB...	24	2	750	750	375	15	9	19	-	130	0.15	1.3
14020xxxxxxxxxC...	12	2	750	750	375	23	15	19	-	130	0.4	4.2
14020xxxxxxxxxD...	24	2	750	750	375	24	16	19	-	130	0.2	2.5
14040xxxxxxxxxA...	12	4	300	150	150	29	20	19	-	130	0.4	1.7
14040xxxxxxxxxB...	24	4	300	150	150	31	24	19	-	130	0.2	0.9
14040xxxxxxxxxC...	12	4	300	100	100	43	36	19	-	130	0.5	2.6
14040xxxxxxxxxD...	24	4	300	100	100	45	38	19	-	130	0.3	1.3

* The typical values can have a variation of $\pm 20\%$ on the current values and $\pm 10\%$ on the speed values. Measurements are made with an actuator in connection with a stable power supply and an ambient temperature at 20°C.



• Self locking ability

To ensure maximum self-locking ability, please be sure that the motor is shorted when stopped. Actuators with integrated controller provide this feature, as long as the actuator is powered.

- When using soft stop on a DC-motor, a short peak of higher voltage will be sent back towards the power supply. It is important when selecting the power supply that it does not turn off the output, when this backwards load dump occurs.

Stroke tolerances

Platform options	Descriptions	Stroke tolerance	Example for 130mm stroke
14XXXXXXXXXX0	With built-in limit switches	+2/- 2mm	128 to 132mm
14XXXXXXXXXX3	Integrated controller	+1/-3mm	127 to 131mm

Built-in tolerances

Platform options	Descriptions	BID tolerance	Example for 245mm BID
14XXXXXXXXXX	All variants	+2/- 2mm	243 to 247mm

LA14 Dimensions

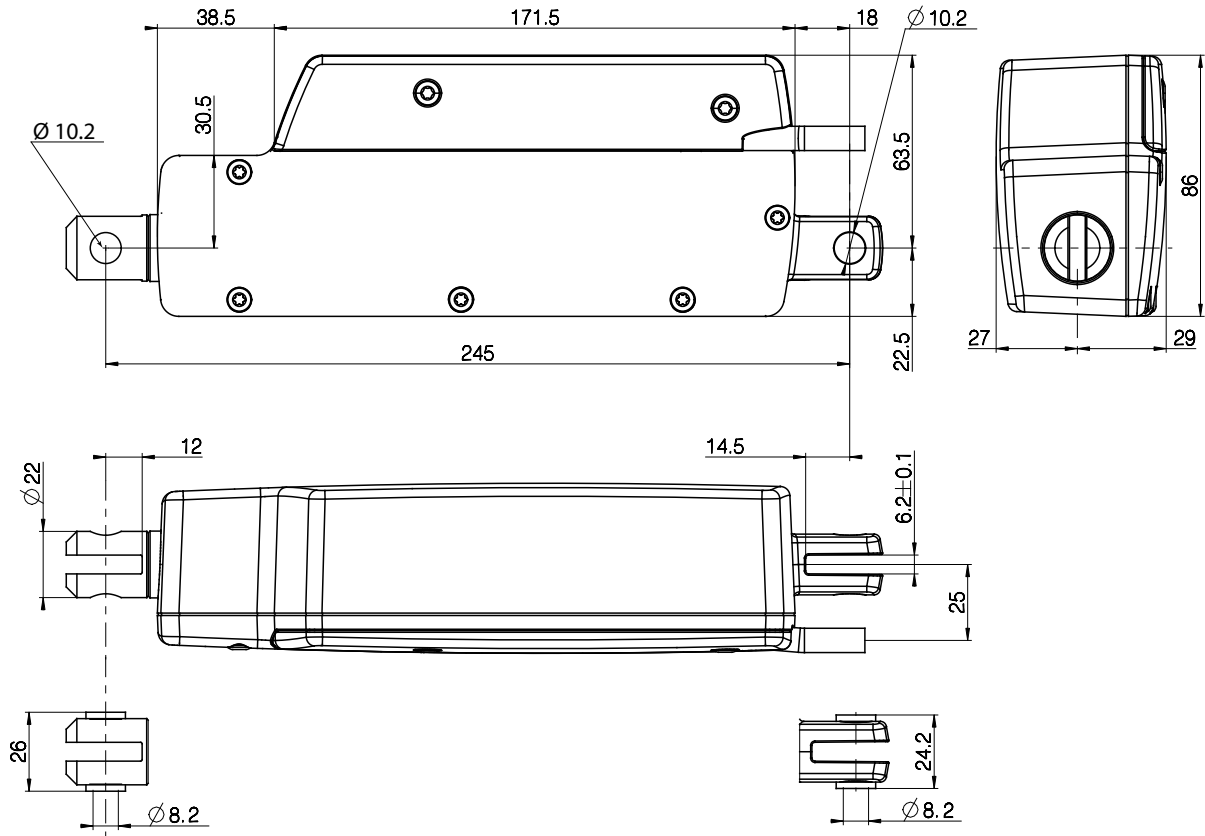

Back fixture orientation

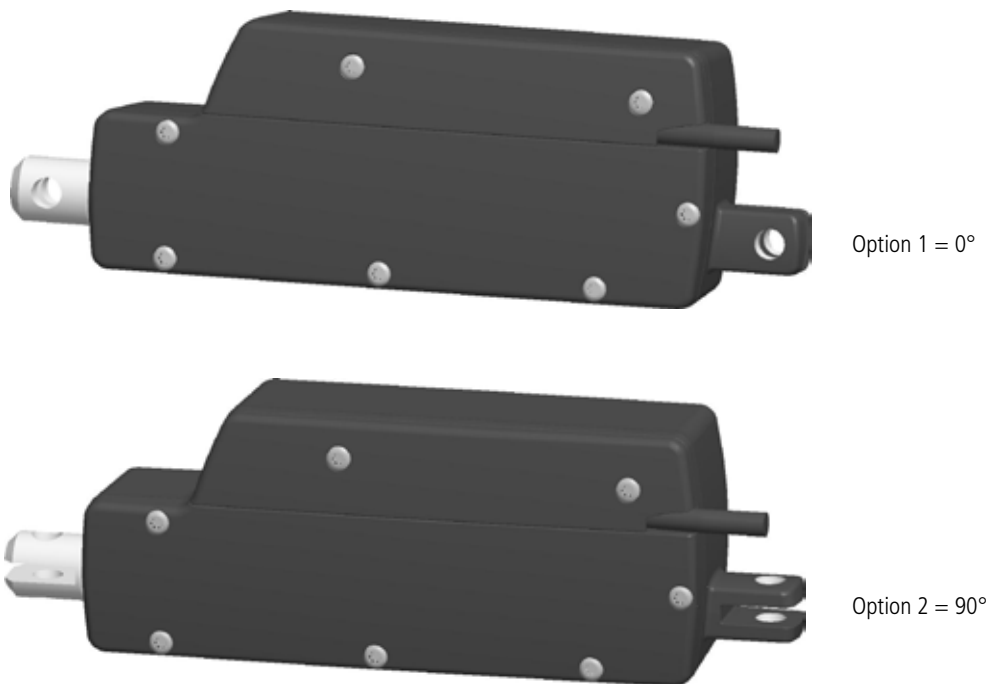

LA14 Piston Rod Eyes

Option "1" and "A"

Piston 0231033, Zinc coated steel

Piston 0231096, Stainless steel AISI 304

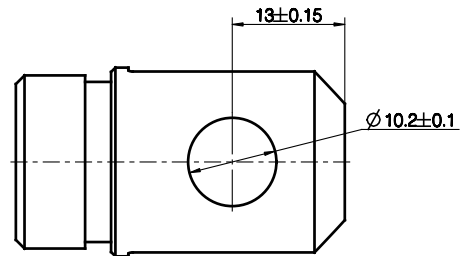
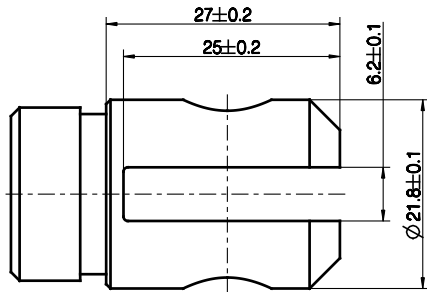

Option "2"

Piston 0231016, Zinc coated steel

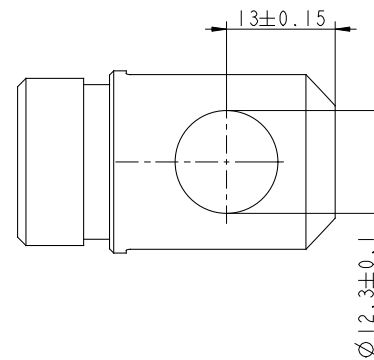
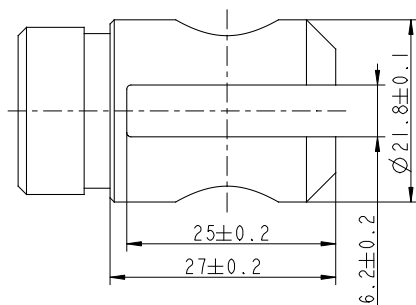

Option "3"

Piston 0301244, Stainless steel AISI 304

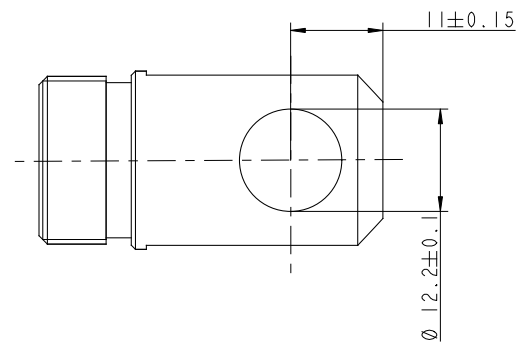
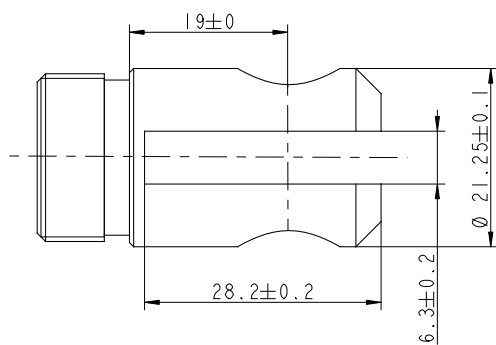

LA14 Piston Rod Eyes

Option "4"
 Piston 031923, Stainless steel AISI 303

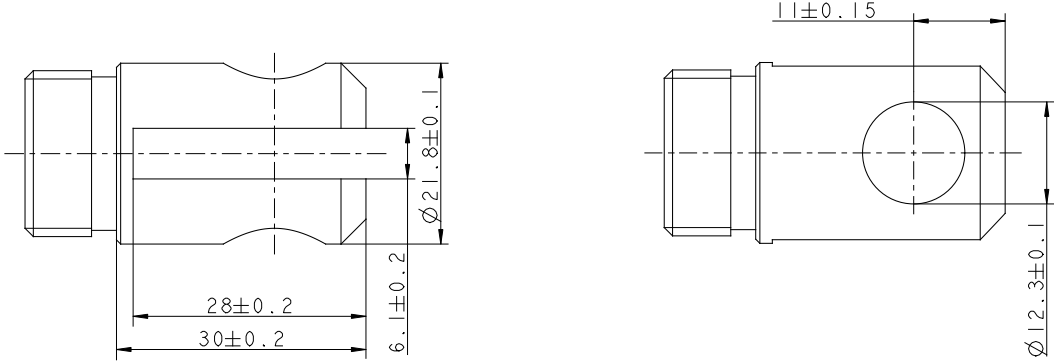

Option "5" and "C"
 Piston 0231033 with bushings, Zinc coated steel
 Piston 0231096 with bushings, Stainless steel AISI 304

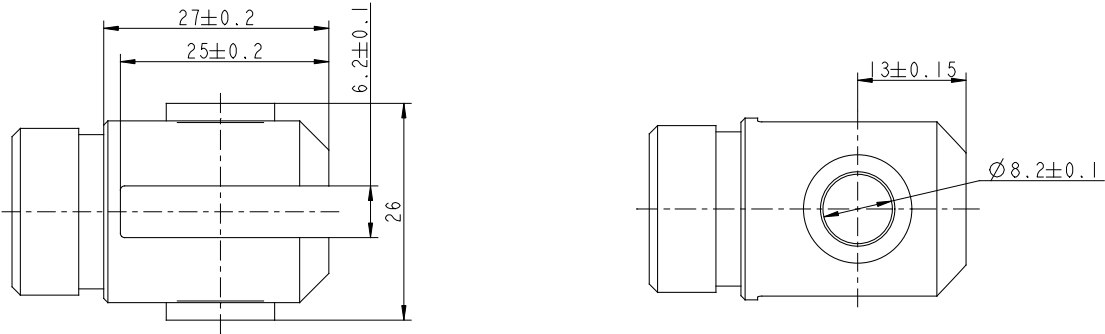

Option "6"
 Piston 0231016 with bushings, Zinc coated steel

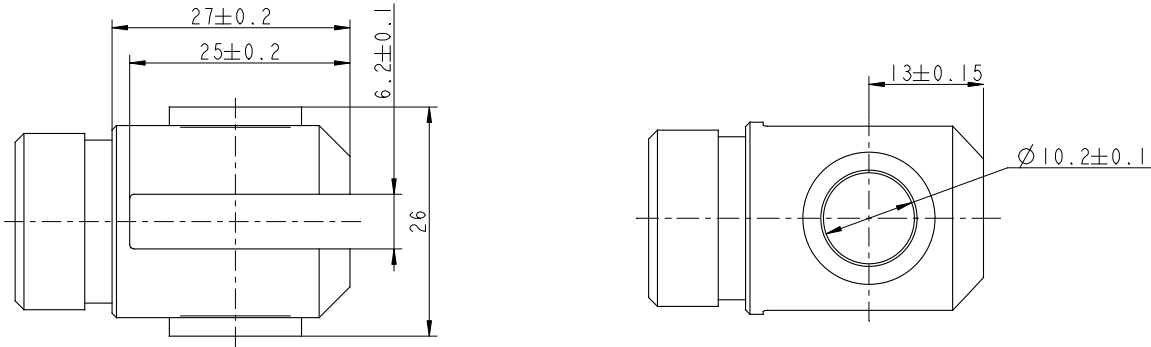

LA14 Piston Rod Eyes

Option "D" and "E"
Piston 0301244 with bushings, Stainless steel AISI 304
Piston 031923 with bushings, Stainless steel AISI 303

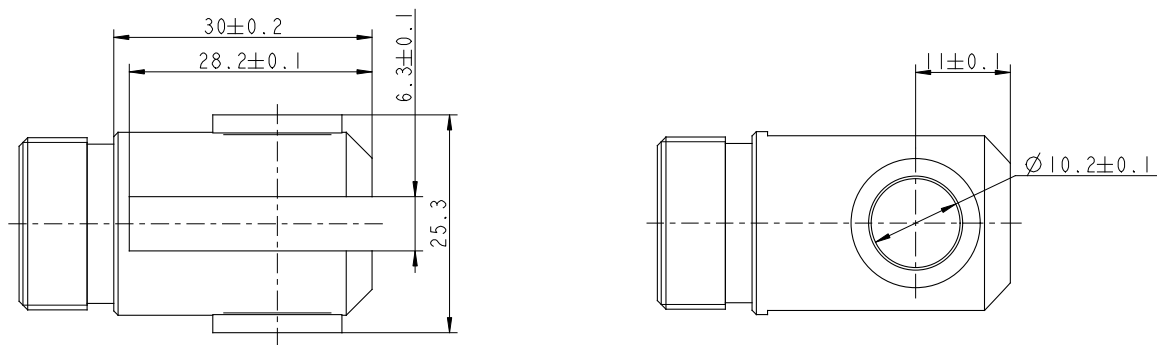

Option "F"
Piston 0251039, Stainless steel AISI 303

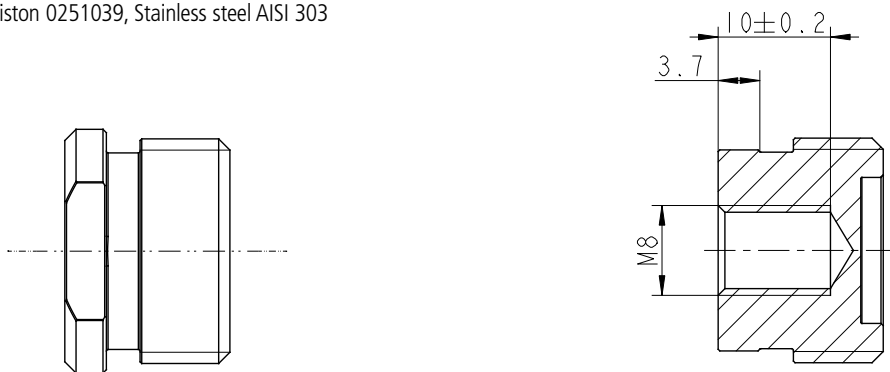

Option "K"
Piston 0351043, Stainless steel AISI 304

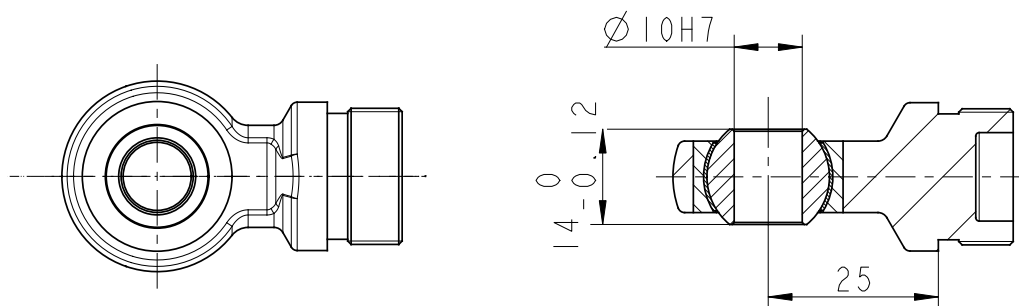

LA14 Piston Rod Eyes

Option "L"
Piston 0351035, Stainless steel AISI 304

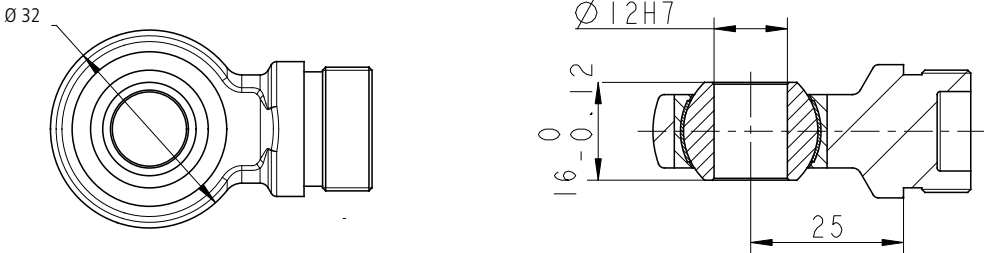

Option "M"
Piston 0231094, Stainless steel AISI 304

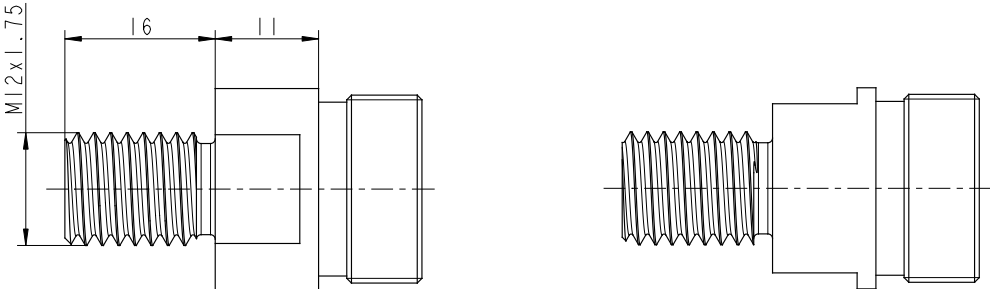

The Piston Rod Eye is only allowed to turn 0 - 90 degrees.

Cable dimensions

Brown: $\varnothing 1.0\text{mm}^2$ AWG*: 18mm
Blue: $\varnothing 1.0\text{mm}^2$ AWG : 18mm
Violet: $\varnothing 1.0\text{mm}^2$ AWG : 18mm
Black: $\varnothing 1.0\text{mm}^2$ AWG : 18mm
Red: $\varnothing 1.0\text{mm}^2$ AWG : 18mm
Yellow: $\varnothing 1.0\text{mm}^2$ AWG : 18mm
Green: $\varnothing 1.0\text{mm}^2$ AWG : 18mm
White: $\varnothing 1.0\text{mm}^2$ AWG : 18mm

*AWG: American Wire Gauge

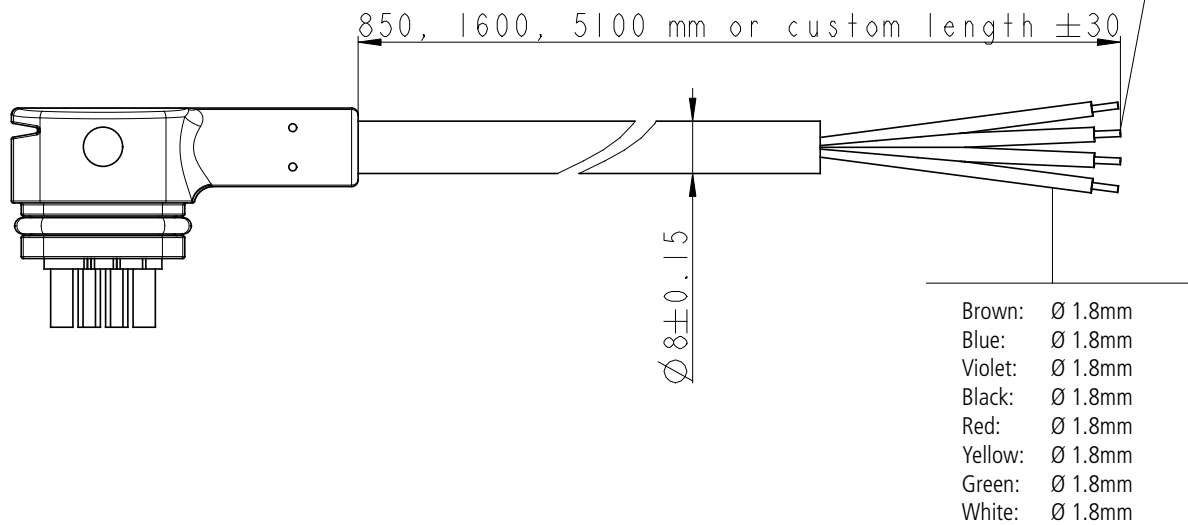

The LA14 standard cable is a UV resistant PVC cable.

Speed and current curves - 12V motor

The values below are typical values and made with a stable power supply and an ambient temperature of 20°C.

LA14 - 12V Speed v's Thrust

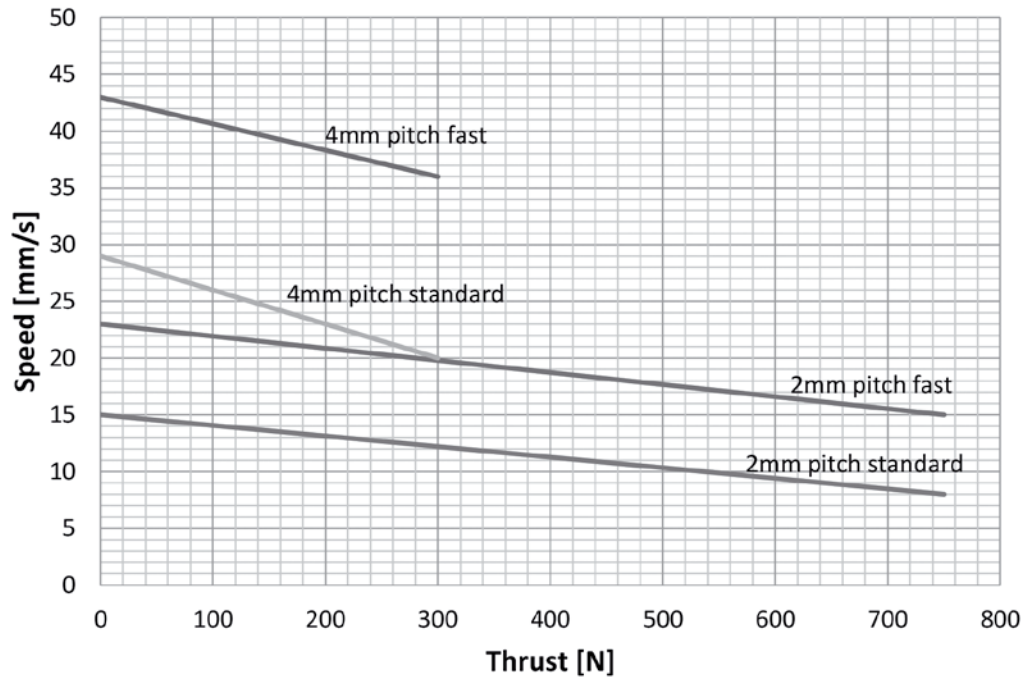

LA14 - 12V Current v's Thrust

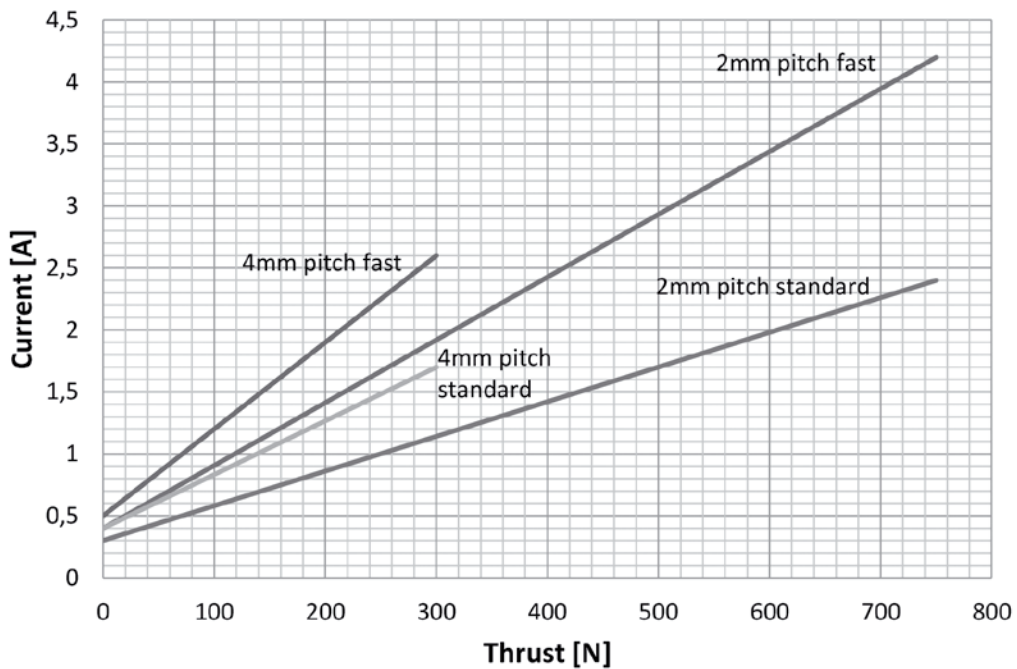

Speed and current curves - 24V motor

The values below are typical values and made with a stable power supply and an ambient temperature of 20°C.

LA14 - 24V Speed v's Thrust

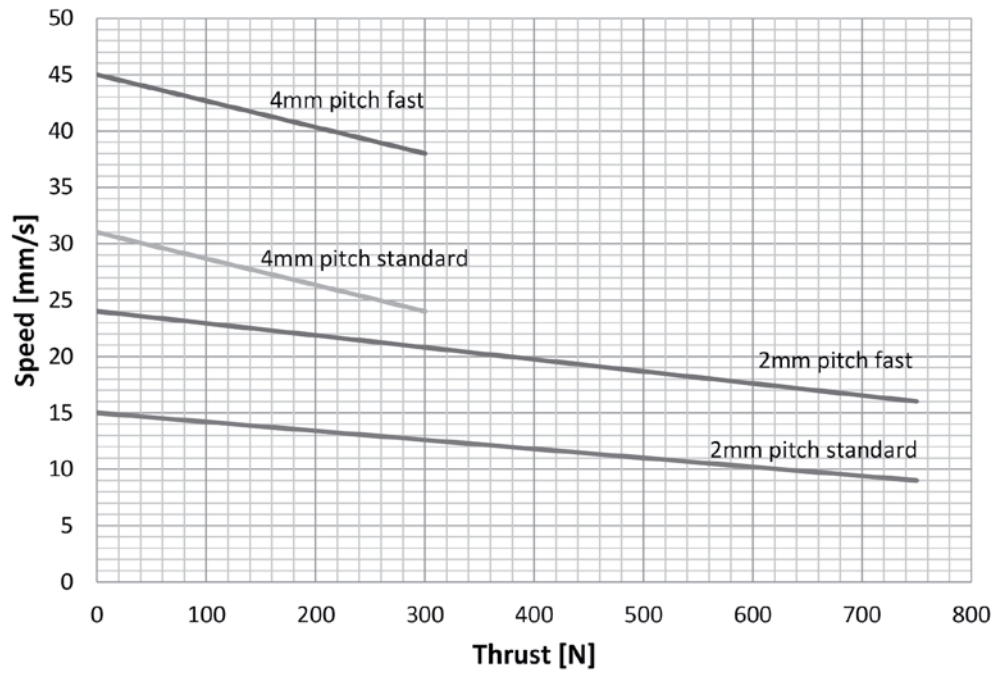

LA14 - 24V Current v's Thrust

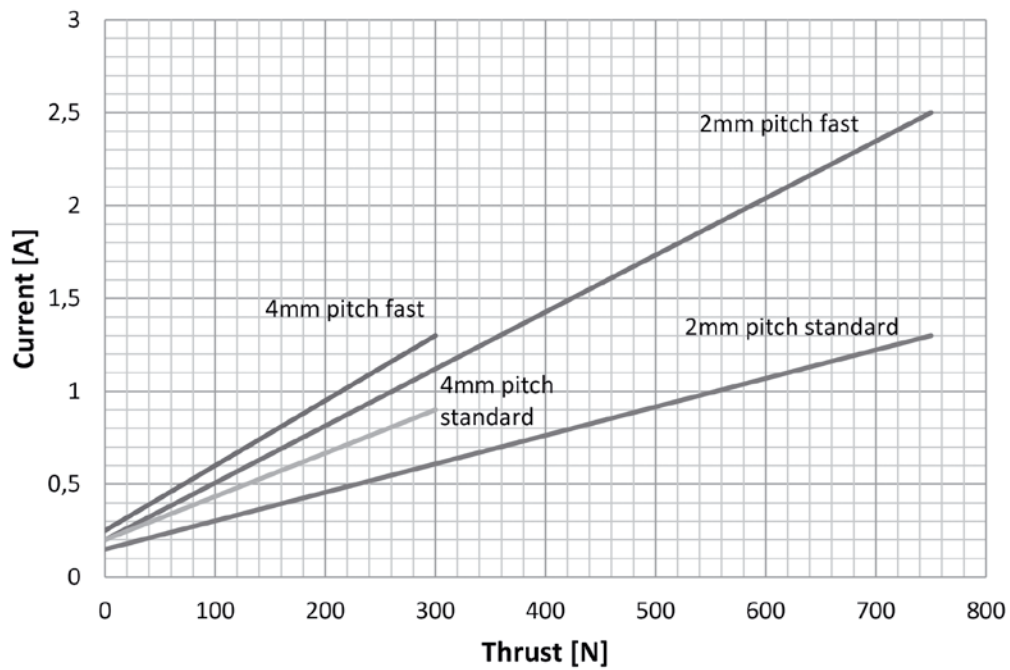

Chapter 2

I/O specifications: Actuator without feedback

Input/Output	Specification	Comments
Description	Permanent magnetic DC motor.	
Brown	12-24VDC (+/-) 12V ± 20% 24V ± 10%	To extend actuator: Connect Brown to positive To retract actuator: Connect Brown to negative
Blue	Under normal conditions: 12V, max. 5A depending on load 24V, max. 2.5A depending on load	To extend actuator: Connect Blue to negative To retract actuator: Connect Blue to positive
Red	Not to be connected	
Black	Not to be connected	
Green	Not to be connected	
Yellow	Not to be connected	
Violet	Not to be connected	
White	Not to be connected	

I/O specifications: Actuator with endstop signals and relative positioning - Single Hall

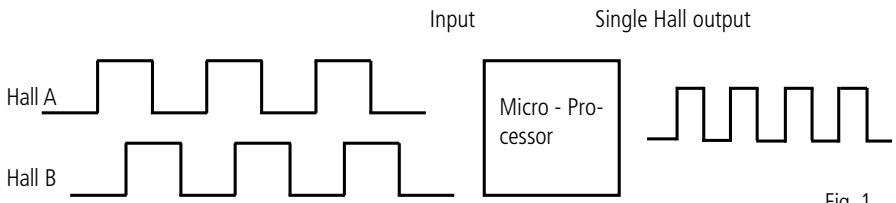
Input/Output	Specification	Comments
Description	The actuator can be equipped with Single Hall that gives a relative positioning feedback signal when the actuator moves.	
Brown	12-24VDC (+/-) 12V ± 20% 24V ± 10%	To extend actuator: Connect Brown to positive To retract actuator: Connect Brown to negative
Blue	Under normal conditions: 12V, max. 5A depending on load 24V, max. 2.5A depending on load	To extend actuator: Connect Blue to negative To retract actuator: Connect Blue to positive
Red	Signal power supply (+) 12-24VDC	Current consumption: Max. 40mA, also when the actuator is not running
Black	Signal power supply GND (-)	
Green	Endstop signal out	Output voltage min. $V_{IN} - 2V$ Source current max. 100mA NOT potential free
Yellow	Endstop signal in	
Violet	Single Hall output (PNP) Movement per single Hall pulse: LA14020 Actuator = 0.2mm per pulse LA14040 Actuator = 0.4mm per pulse Frequency: Frequency is 14-26Hz on Single Hall output depending on load. Every pulse is "ON" for minimum 3ms. Overvoltage on the motor can result in shorter pulses.	Output voltage min. $V_{IN} - 2V$ Max. current output: 12mA Max. 680nF N.B. For more precise measurements, please contact LINAK A/S. Low frequency with a high load. Higher frequency with no load.
	<p>Diagram of Single Hall:</p> 	
White	Not to be connected	

I/O specifications: Actuator with endstop signals and absolute positioning - Analogue feedback

Input/Output	Specification	Comments
Description	The actuator can be equipped with electronic circuit that gives an analogue feedback signal when the actuator moves.	
Brown	12-24VDC (+/-) 12V ± 20% 24V ± 10%	To extend actuator: Connect Brown to positive To retract actuator: Connect Brown to negative
Blue	Under normal conditions: 12V, max. 5A depending on load 24V, max. 2.5A depending on load	To extend actuator: Connect Blue to negative To retract actuator: Connect Blue to positive
Red	Signal power supply (+) 12-24VDC	Current consumption: Max. 60mA, also when the actuator is not running
Black	Signal power supply GND (-)	
Green	Endstop signal out	Output voltage min. $V_{IN} - 2V$ Source current max. 100mA NOT potential free
Yellow	Endstop signal in	
Violet	Analogue feedback 0-10V (Option A) 0.5-4.5V (Option B) Special (Option F)	Tolerances +/- 0.2V Max. current output: 1mA Ripple max. 200mV Transaction delay 20ms Linear feedback 0.5%
	4-20mA (Option C) Special (Option F)	Tolerances +/- 0.2mA Transaction delay 20ms Linear feedback 0.5% Output: Source Serial resistance: 12V max. 300 ohm 24V max. 900 ohm
	For all analogue feedbacks it is recommendable to have the actuator to activate its limit switches on a regular basis, to ensure more precise positioning	
White	Not to be connected	

I/O specifications: Actuator with absolute positioning - Mechanical potentiometer feedback

Input/Output	Specification	Comments
Description	The actuator can be equipped with mechanical potentiometer that gives an analogue feedback signal when the actuator moves.	
Brown	12-24VDC (+/-) 12V ± 20% 24V ± 10%	To extend actuator: Connect Brown to positive To retract actuator: Connect Brown to negative
Blue	Under normal conditions: 12V, max. 5A depending on load 24V, max. 2.5A depending on load	To extend actuator: Connect Blue to negative To retract actuator: Connect Blue to positive
Red	Signal power supply (+)	+10V or other value
Black	Signal power supply GND (-)	
Green	Not to be connected	
Yellow	Not to be connected	
Violet	Analogue feedback Slide potentiometer, 10 kohm 1 kohm = 0mm stroke 11 kohm = 100mm stroke The maximum effect: 0.1W	Linearity: ± 20% Minimum lifetime: 15,000 cycles Average lifetime: 40,000 cycles Max. current output: 1mA
White	Not to be connected	

I/O specifications: Actuator with endstop signals and absolute positioning - PWM

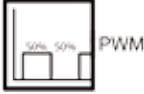
Input/Output	Specification	Comments
Description	The actuator can be equipped with electronic circuit that gives an analogue feedback signal when the actuator moves.	
Brown	12-24VDC (+/-) 12V ± 20% 24V ± 10%	To extend actuator: Connect Brown to positive To retract actuator: Connect Brown to negative
Blue	Under normal conditions: 12V, max. 5A depending on load 24V, max. 2.5A depending on load	To extend actuator: Connect Blue to negative To retract actuator: Connect Blue to positive
Red	Signal power supply (+) 12-24VDC	Current consumption: Max. 40mA, also when the actuator is not running
Black	Signal power supply GND (-)	
Green	Endstop signal out	Output voltage min. $V_{IN} - 2V$ Source current max. 100mA NOT potential free
Yellow	Endstop signal in	
Violet	Digital output feedback 10-90% (Option D) 20-80% (Option E) Special (Option F)	Output voltage min. $V_{IN} - 2V$ Tolerances +/- 2% Max. current output: 12mA It is recommendable to have the actuator to activate its limit switches on a regular basis, to ensure more precise positioning
White	Not to be connected	

I/O specifications: Actuator with IC Basic

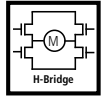
Input/Output	Specification	Comments						
Description	<p>Easy to use interface with integrated power electronics (H-bridge).</p> <p>The actuator can also be equipped with electronic circuit that gives an absolute or relative feedback signal.</p> <p>The version with "IC option" cannot be operated with PWM (power supply).</p>							
Brown	<p>12-24VDC + (VCC) Connect Brown to positive</p> <p>12V ± 20% 24V ± 10%</p> <table border="0"> <tr> <td>Standard motor</td> <td>Fast motor</td> </tr> <tr> <td>12V, current limit 8A</td> <td>12V, current limit 8A</td> </tr> <tr> <td>24V, current limit 5A</td> <td>24V, current limit 5A</td> </tr> </table>	Standard motor	Fast motor	12V, current limit 8A	12V, current limit 8A	24V, current limit 5A	24V, current limit 5A	<p>Note: Do not change the power supply polarity on the brown and blue wires!</p> <p>Power supply GND (-) is electrically connected to the housing</p> <p>If the temperature drops below -10°C, all current limits will automatically increase to 9A</p>
Standard motor	Fast motor							
12V, current limit 8A	12V, current limit 8A							
24V, current limit 5A	24V, current limit 5A							
Blue	<p>12-24VDC - (GND) Connect Blue to negative</p> <p>12V ± 20% 24V ± 10%</p> <table border="0"> <tr> <td>Standard motor</td> <td>Fast motor</td> </tr> <tr> <td>12V, current limit 8A</td> <td>12V, current limit 8A</td> </tr> <tr> <td>24V, current limit 5A</td> <td>24V, current limit 5A</td> </tr> </table>	Standard motor	Fast motor	12V, current limit 8A	12V, current limit 8A	24V, current limit 5A	24V, current limit 5A	
Standard motor	Fast motor							
12V, current limit 8A	12V, current limit 8A							
24V, current limit 5A	24V, current limit 5A							
Red	Extends the actuator	<p>On/off voltages:</p> <p>> 67% of V_{IN} = ON</p> <p>< 33% of V_{IN} = OFF</p> <p>Input current: 10 mA</p>						
Black	Retracts the actuator							
Green	Not to be connected							
Yellow	Not to be connected							
Violet	<p>Analogue feedback</p> <p>0-10V (Option A)</p>	<p>Standby power consumption: 12V, 60mA 24V, 45mA</p> <p>Ripple max. 200mV Transaction delay 20ms Linear feedback 0.5% Max. current output: 1mA</p> <p>It is recommendable to have the actuator to activate its limit switches on a regular basis, to ensure more precise positioning.</p>						
	<p>Single Hall output (PNP)</p> <p>Movement per single Hall pulse: LA14020 Actuator = 0.2 mm per pulse LA14040 Actuator = 0.4 mm per pulse</p> <p>Frequency: Frequency is 14-26 Hz on Single Hall output depending on load. Every pulse is "ON" for minimum 3ms. Overvoltage on the motor can result in shorter pulses.</p>	<p>Output voltage min. $V_{IN} - 2V$ Max. current output: 12mA Max. 680nF</p>						
White	Signal GND							

I/O specifications: Actuator with IC Advanced - with BusLink

Input/Output	Specification	Comments						
Description	<p>Easy to use interface with integrated power electronics (H-bridge). The actuator can also be equipped with electronic circuit that gives an absolute or relative feedback signal. IC Advanced also provides a wide range of possibilities for customisation.</p> <p>The version with "IC option" cannot be operated with PWM (power supply).</p>							
Brown	<p>12-24VDC + (VCC) Connect Brown to positive</p> <p>12V ± 20% 24V ± 10%</p> <table border="0"> <tr> <td>Standard motor</td> <td>Fast motor</td> </tr> <tr> <td>12V, current limit 8A</td> <td>12V, current limit 8A</td> </tr> <tr> <td>24V, current limit 5A</td> <td>24V, current limit 5A</td> </tr> </table>	Standard motor	Fast motor	12V, current limit 8A	12V, current limit 8A	24V, current limit 5A	24V, current limit 5A	<p>Note: Do not change the power supply polarity on the brown and blue wires!</p> <p>Power supply GND (-) is electrically connected to the housing</p>
Standard motor	Fast motor							
12V, current limit 8A	12V, current limit 8A							
24V, current limit 5A	24V, current limit 5A							
Blue	<p>12-24VDC - (GND) Connect Blue to negative</p> <p>12V ± 20% 24V ± 10%</p> <table border="0"> <tr> <td>Standard motor</td> <td>Fast motor</td> </tr> <tr> <td>12V, current limit 8A</td> <td>12V, current limit 8A</td> </tr> <tr> <td>24V, current limit 5A</td> <td>24V, current limit 5A</td> </tr> </table>	Standard motor	Fast motor	12V, current limit 8A	12V, current limit 8A	24V, current limit 5A	24V, current limit 5A	<p>Current limit levels can be adjusted through BusLink</p> <p>If the temperature drops below -10°C, all current limits will automatically increase to 9A</p>
Standard motor	Fast motor							
12V, current limit 8A	12V, current limit 8A							
24V, current limit 5A	24V, current limit 5A							
Red	Extends the actuator	On/off voltages:						
Black	Retracts the actuator	<p>> 67% of V_{IN} = ON < 33% of V_{IN} = OFF Input current: 10mA</p>						
Green	Endstop signal out	<p>Output voltage min. $V_{IN} - 2V$ Source current max. 100mA</p> <p>Endstop signals are NOT potential free. Endstop signals can be configured with BusLink software according to any position needed</p>						
Yellow	Endstop signal in	<p>When configuring virtual endstop, it is not necessary to choose the position feedback</p> <p>EOS and virtual endstop will work even when feedback is not chosen</p>						

I/O specifications: Actuator with IC Advanced - with BusLink

Input/Output	Specification	Comments
Violet	Analogue feedback (0-10V): Configure any high/low combination between 0-10V 0-10V (Option G) 0.5-4.5V (Option H) Special (Option X)	Ripple max. 200mV Transaction delay 20ms Linear feedback 0.5% Max. current output. 1mA
	Single Hall output (PNP) Movement per single Hall pulse: LA14020 Actuator = 0.2 mm per pulse LA14040 Actuator = 0.4 mm per pulse Frequency: Frequency is 14-26 Hz on Single Hall output depending on load. Every pulse is "ON" for minimum 3ms. Overvoltage on the motor can result in shorter pulses.	Output voltage min. $V_{IN} - 2V$ Max current output: 12mA Max. 680nF
	Digital output feedback PWM: Configure any high/low combination between 0-100% 10-90% (Option K) 20-80% (Option L) Special (Option X)	Output voltage min. $V_{IN} - 2V$ Frequency: 75Hz \pm 10Hz as standard, but this can be customised. Duty cycle: Any low/high combination between 0 and 100 percent. Open collector source current max. 12mA
	Analogue feedback (4-20mA): Configure any high/low combination between 4-20mA 4-20mA (Option J) Special (Option X)	Tolerances \pm 0.2mA Transaction delay 20ms Linear feedback 0.5% Output: Source Serial resistance: 12V max. 300 ohm 24V max. 900 ohm
	All absolute value feedbacks (0-10V, PWM and 4-20mA)	Standby power consumption: 12V, 60mA 24V, 45mA It is recommendable to have the actuator to activate its limit switches on a regular basis, to ensure more precise positioning
White	Signal GND	



The BusLink software tool is available for IC Advanced and can be used for:

Diagnostics, manual run and configuration.

Please note that the BusLink cables must be purchased separately from the actuator!

Item number for BusLink cable kit: 0147999 (adaptor + USB2Lin)

I/O specifications: Actuator with Parallel

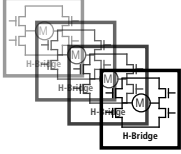
Input/Output	Specification	Comments						
Description	<p>Parallel drive of up to 8 actuators. A master actuator with an integrated H-bridge controller controls up to 7 slaves.</p> <p>The version with "IC option" cannot be operated with PWM (power supply).</p>							
Brown	<p>12-24VDC + (VCC) Connect Brown to positive</p> <p>12V ± 20% 24V ± 10%</p> <table border="0"> <tr> <td>Standard motor</td> <td>Fast motor</td> </tr> <tr> <td>12V, current limit 8A</td> <td>12V, current limit 8A</td> </tr> <tr> <td>24V, current limit 5A</td> <td>24V, current limit 5A</td> </tr> </table>	Standard motor	Fast motor	12V, current limit 8A	12V, current limit 8A	24V, current limit 5A	24V, current limit 5A	<p>Note: Do not change the power supply polarity on the brown and blue wires!</p> <p>The parallel actuators can run on one OR separate power supplies</p> <p>Power supply GND (-) is electrically connected to the housing</p>
Standard motor	Fast motor							
12V, current limit 8A	12V, current limit 8A							
24V, current limit 5A	24V, current limit 5A							
Blue	<p>12-24VDC - (GND) Connect Blue to negative</p> <p>12V ± 20% 24V ± 10%</p> <table border="0"> <tr> <td>Standard motor</td> <td>Fast motor</td> </tr> <tr> <td>12V, current limit 8A</td> <td>12V, current limit 8A</td> </tr> <tr> <td>24V, current limit 5A</td> <td>24V, current limit 5A</td> </tr> </table>	Standard motor	Fast motor	12V, current limit 8A	12V, current limit 8A	24V, current limit 5A	24V, current limit 5A	<p>Current limit levels can be adjusted through Bus-Link (only one actuator at a time for parallel)</p> <p>If the temperature drops below -10°C, all current limits will automatically increase to 9A</p>
Standard motor	Fast motor							
12V, current limit 8A	12V, current limit 8A							
24V, current limit 5A	24V, current limit 5A							
Red	Extends the actuator	<p>On/off voltages:</p> <p>> 67% of V_{IN} = ON < 33% of V_{IN} = OFF</p> <p>Input current: 10mA</p>						
Black	Retracts the actuator	<p>It does not matter where the in/out signals are applied. You can either choose to connect the signal cable to one actuator OR you can choose to connect the signal cable to each actuator on the line. Either way this will ensure parallel drive</p>						
Green	Endstop signal out	<p>Output voltage min. $V_{IN} - 2V$ Source current max. 100 mA</p>						
Yellow	Endstop signal in	<p>Endstop signals are NOT potential free. Endstop signals can be configured with BusLink software according to any position needed</p>						
Violet	<p>Parallel communication: Violet cords must be connected together</p>	<p>Standby power consumption: 12V, 60mA 24V, 45mA</p> <p>No feedback available during parallel drive</p>						
White	<p>Signal GND: White cords must be connected together</p>							



The BusLink software tool is available for Parallel and can be used for:

Diagnostics, manual run and configuration.

Please note that the BusLink cables must be purchased separately from the actuator!

Item number for BusLink cable kit: 0147999 (adaptor + USB2Lin)

IC options overview

	Basic	Advanced	Parallel	LIN bus
Control				
12V, 24V supply	√	√	√	√
H-bridge	√	√	√	√
Manual drive in/out	√	√	√	√
EOS in/out	-	√	√	√
Soft start/stop	√	√	√	√
Feedback				
Voltage	√	√ *	-	-
Current	-	√ **	-	-
Single Hall	√	√	-	-
PWM	-	√	-	-
Position (mm)	-	-	-	√
Custom feedback type	-	√	-	-
Monitoring				
Temperature monitoring	√	√	√	√
Current cut-off	√	√	√	√
Ready signal	-	-	-	-
BusLink (…)				
Service counter	-	√	√	√
Custom soft start/stop	-	√ ***	√ ***	√ ***
Custom current limit	√	√	√	
Speed setting	-	√	√	√
Virtual end stop	-	√	√	√

* Configure any high/low combination between 0 - 10V

** Configure any high/low combination between 4 - 20mA

*** Configure any value between 0 - 30s

Feedback configurations available for IC Basic, IC Advanced and Parallel

	Pre-configured	Customised range	Pros	Cons
None			N/A	N/A
PWM Feedback	10 – 90 % 75 Hz	0 – 100 % 75 – 150 Hz	Suitable for long distance transmission. Effectual immunity to electrical noise.	More complex processing required, compared to AFV and AFC.
Single Hall*	N/A	N/A	Suitable for long distance transmission.	No position indication.
Analogue Feedback Voltage (AFV)*	0 - 10V	Any combination, going negative or positive. E.g. 8.5 – 2.2V over a full stroke.	High resolution. Traditional type of feedback suitable for most PLCs. Easy faultfinding. Independent on stroke length, compared to a traditional mechanical potentiometer.	Not recommended for applications with long distance cables or environments exposed to electrical noise.
Analogue Feedback Current (AFC)	4 - 20mA	Any combination, going negative or positive. E.g. 5.5 – 18mA over a full stroke.	High resolution. Better immunity to long cables and differences in potentials than AFV. Provides inherent error condition detection. Independent on stroke length, compared to a traditional mechanical potentiometer.	Not suitable for signal isolation.
Endstop signal in/out**	At physical end stops. Default for IC Advanced.	Any position.	Can be set at any position over the full stroke length.	Only one endstop can be customised.



All feedback configurations are available for IC Advanced.

* IC Basic feedback configurations available: Single Hall and 0-10V

** Parallel feedback configurations available: EOS

Actuator configurations available for IC Basic, IC Advanced and Parallel

	Pre-configured	Customised range	Description
Current limit inwards	20A for both current limit directions. (When the current outputs are at zero, it means that they are at maximum value 20A). Be aware: When the actuator comes with current cut-off limits that are factory pre-configured for certain values, the pre-configured values will be the new maximum level of current cut-off. This means that if the current cut-off limits are pre-configured to 14A, it will not be possible to change the current limits through BusLink to go higher than 14A.	Recommended range: 4A to 20A If the temperature drops below 0°C, all current limits will automatically increase to approximately 30A, independent of the pre-configured value.	The actuator's unloaded current consumption is very close to 4A, and if the current cut-off is customised below 4A there is a risk that the actuator will not start. The inwards and outwards current limits can be configured separately and do not have to have the same value.
Current limit outwards			
Max. speed inwards/ outwards	100% equal to full performance. Please note: for parallel actuators the full performance equals 80% of the max. speed.	Lowest recommended speed at full load: 60% It is possible to reduce the speed below 60%, but this is dependable on load, power supply and the environment.	The speed is based on a PWM principle, meaning that 100% equals the voltage output of the power supply in use, and not the actual speed.
Virtual endstop inwards	0mm for both virtual endstop directions. (When the virtual endstops are at zero, it means that they are not in use).	It is only possible to run the actuator with one virtual endstop, either inwards or outwards.	The virtual endstop positions are based on hall sensor technology, meaning that the positioning needs to be initialised from time to time. One of the physical endstops must be available for initialisation.
Virtual endstop outwards			
Soft stop inwards	0.3 sec. for both soft stop directions.	0.3 sec. to 30 sec. 0 sec. can be chosen for hard stop.	It is not possible to configure values between 0.01 sec. to 0.29 sec. This is due to the back-EMF from the motor (increasing the voltage). Be aware that the soft stop value equals the deceleration time after stop command.
Soft stop outwards			
Soft start inwards	0.3 sec. for both soft start directions.	0 sec. to 30 sec.	Be aware that the soft start value equals the acceleration time after start command. To avoid stress on the actuator, it is not recommended to use 0 sec. for soft start, due to higher inrush current.
Soft start outwards			

Chapter 3

Environmental tests - Climatic

Test	Specification	Comment
Cold test	EN60068-2-1 (Ab)	Storage at low temperature: Temperature: - 40°C Duration: 72 h Actuator is not connected/operated Tested at room temperature
	EN60068-2-1 (Ad)	Storage at low temperature: Temperature: -55°C Duration: 24 h Actuator is not connected Tested at room temperature
	EN60068-2-1 (Ad)	Operating at low temperature: Temperature: -40°C Duration: 4 h Tested at room temperature within 5 minutes overload
Dry heat	EN60068-2-2 (Bb)	Storage at high temperature: Temperature: +85°C Duration: 72 h Actuator is not connected/operated Tested at room temperature
	EN60068-2-2 (Bd)	Operating at high temperature: Temperature: +85°C Duration: 96 h Actuator operated at high temperature
Damp heat	EN60068-2-30 (Db)	Damp heat, Cyclic: Relative humidity: 93 - 98% High temperature: +55°C in 12 hours Low temperature: +25°C in 12 hours Duration: 21 cycles * 24 hours Actuator is operated during test
Salt mist.	EN ISO 9227	Dynamic salt spray test: Salt solution: 5% sodium chloride (NaCl) Temperature: 35 ± 2°C Duration: 500 h Actuator is operated
Thermal shock		Dunk test: Actuator is heated to +85°C for 4 h and submerged into a 0°C cold salt-water-detergent solution for 2 h Followed by 18 h dry time Duration: 5 cycles
Chemicals	BS7691 / 96 hours	Diesel 100% Hydraulic oil 100% Ethylene Glucol 50% Urea Nitrogen saturated solution Liquid lime 10% (Super - Cal) NPK Fertiliser (NPK 16-4-12) saturated Diesel exhaust fluid (DEF) 100% Tested for corrosion

Environmental tests - Climatic

Degrees of protection	EN60529 - IP66	IP6X - Dust: Dust-tight, No ingress of dust Actuator is not activated
	EN60529 - IP66	IPX6 - Water: Ingress of water in quantities causing harmful effects is not allowed Duration: 100 litres pr. minute in 3 minutes Actuator is not activated
	DIN40050 - IP69K	IPX9K: High pressure cleaner Temperature: +80°C Water pressure: 80 - 100 bar Water flow: 14 - 16 l/min Duration: 30 sec. each at 4 different angles 0°, 30°, 60° and 90° Actuator is not activated Ingress of water in quantities causing harmful effects is not allowed
Rain		Dynamic rain test: Actuators exposed to continuous rain Actuators operated and side loaded with 10 N Duration: 10.000 cycles and 240 h

Environmental tests - Mechanical

Test	Specification	Comment
Free fall		3 drops on 6 faces onto a steel plate Drop height: 300 mm onto the piston rod eye, 500 mm on all other faces
Shock	EN60068-2-27:2009	Peak Pulse Amplitude: 50 G Pulse Duration: 11 ms Number of pulses: 18 total - 3 in each direction for all three axis
Shock	EN60068-2-27:2009	Peak Pulse Amplitude: 30 G Pulse Duration: 18 ms Number of pulses: 18 total - 3 in each direction for all three axis
Shock	EN60068-2-27:2009	Peak Pulse Amplitude: 25 G Pulse Duration: 6 ms Number of pulses: 6000 total - 1000 in each direction for all three axis
Random Vibration	EN60068-2-64:2008	Frequency: 18 Hz to 1000 Hz ASD amplitudes: 18 Hz 0.025 g ² /Hz 150 Hz 0.015 g ² /Hz 1000 Hz 0.0015 g ² /Hz Duration: 2 h/axis

Environmental tests - Electrical

Standard	Specification	FOCUS ON
2004/104/EC	Automotive EMC Directive 2004/104/EC on electrical and electronic car components	<ul style="list-style-type: none"> VEHICLES AND MOBILITY
EN/IEC 60204-1: 2006 +A1: 2009	Safety of machinery - Electrical equipment of machines - Part 1: General requirements	<ul style="list-style-type: none"> INDUSTRIAL AUTOMATION
EN/IEC 60204-32: 2008	Safety of machinery - Electrical equipment of machines - Part 32: Requirements for hoisting machines	<ul style="list-style-type: none"> INDUSTRIAL AUTOMATION PLATFORMS AND LIFTS
EN/IEC 61000-6-1: 2007	Electromagnetic compatibility (EMC) - Part 6-1: Generic standards - Immunity for residential, commercial and light-industrial environments	<ul style="list-style-type: none"> INDUSTRIAL AUTOMATION
EN/IEC 61000-6-2: 2005	Electromagnetic compatibility (EMC) - Part 6-2: Generic standards - Immunity for industrial environments	<ul style="list-style-type: none"> INDUSTRIAL AUTOMATION
EN/IEC 61000-6-3: 2007 + A1:2011	Electromagnetic compatibility (EMC) - Part 6-3: Generic standards - Emission standard for residential, commercial and light-industrial environments	<ul style="list-style-type: none"> INDUSTRIAL AUTOMATION
EN/IEC 61000-6-4: 2007 + A1:2011	Electromagnetic compatibility (EMC) - Part 6: Generic standards - Section 4: Emission standard for industrial environments	<ul style="list-style-type: none"> INDUSTRIAL AUTOMATION
EN 13309: 2010	Construction machinery	<ul style="list-style-type: none"> CONSTRUCTION
EN/ISO 13766: 2006	Earth-moving machinery - Electromagnetic compatibility	<ul style="list-style-type: none"> CONSTRUCTION
EN/ISO 14982: 2009	Agricultural and forestry machines - Electromagnetic compatibility	<ul style="list-style-type: none"> MOBILE AGRICULTURE OUTDOOR POWER EQUIPMENT
EU recreational crafts directive 94/25/EC		
IECEX / ATEX (Ex) EN60079-0:2012 EN60079-31:2014	This Ex certification allows the actuator to be mounted in Ex dust areas: II 2D Ex tb IIIC T135°C Db Tamb -25°C to +65°C	
Regulation No. 10	Directive on electromagnetic compatibility of sub-assembly for automotive applications	<ul style="list-style-type: none"> AUTOMOTIVE APPLICATIONS



All electrical tests are conducted and radiated emission (EMC) tests.

Non-complying standards

Standard	Explanation
IEC 60601-1	Please note that this product cannot be approved according to the medical electrical equipment standard. Due to the combination of the aluminium cast housing and the embedded PCB, we do not fulfill the regulations according to leakage current.

Terms of use

The user is responsible for determining the suitability of LINAK products for specific application. LINAK takes great care in providing accurate and up-to-date information on its products.

However, due to continuous development in order to improve its products, LINAK products are subject to frequent modifications and changes without prior notice. Therefore, LINAK cannot guarantee the correct and actual status of said information on its products.

While LINAK uses its best efforts to fulfill orders, LINAK cannot, for the same reasons as mentioned above, guarantee the availability of any particular product. Therefore, LINAK reserves the right to discontinue the sale of any product displayed on its website or listed in its catalogues or other written material drawn up by LINAK.

All sales are subject to the Standard Terms of Sale and Delivery for LINAK. For a copy hereof, please contact LINAK.