

Art.Code	L (mm)	Ls (mm)	K (mm)	D (mm)	H (mm)	B (mm)	M (mm)	d (mm)	Shore A
6001203143	170	140	90	106	39	110	M12i	13	40°
6001203157	170	140	90	106	39	110	M12i	13	55°
6001203168	170	140	90	106	39	110	M12i	13	70°

Indien gewenst is de machinevoet leverbaar met hoogteverstelling

- L = lengte
- Ls = hartafstand bevestigingsgaten
- K = diameter kap
- D = diameter
- H = hoogte
- B = breedte
- M = schroefdraad
- d = boring
- Shore A = hardheid

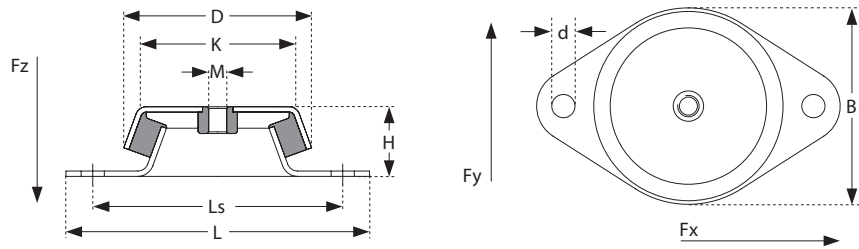

Belasting Fx, Fy

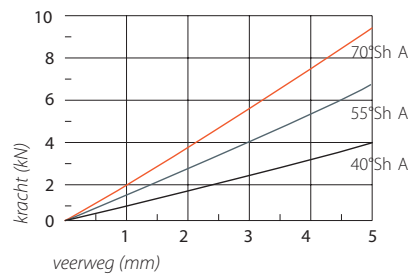

Art.Code	L (mm)	Ls (mm)	K (mm)	D (mm)	H (mm)	B (mm)	M (mm)	d (mm)	Shore A
6001603243	168	132	113	150	51,5	168	M16i	12,5	40°
6001603257	168	132	113	150	51,5	168	M16i	12,5	55°
6001603268	168	132	113	150	51,5	168	M16i	12,5	70°

Indien gewenst is de machinevoet leverbaar met hoogteverstelling

- L = lengte
- Ls = hartafstand bevestigingsgaten
- K = diameter kap
- D = diameter
- H = hoogte
- B = breedte
- M = schroefdraad
- d = boring
- Shore A = hardheid

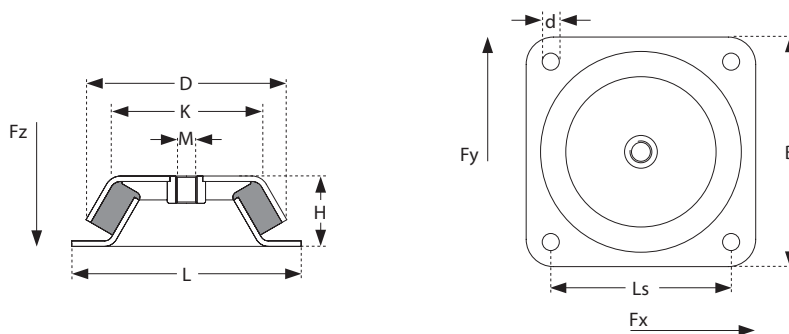

### Belasting Fz

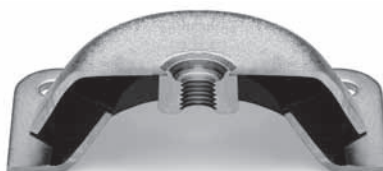
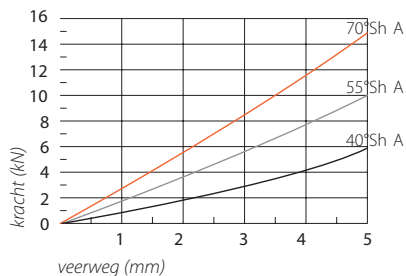

Art.Code	L (mm)	Ls (mm)	K (mm)	D (mm)	H (mm)	B (mm)	M (mm)	d (mm)	Shore A
6001703343	220	180	110	150	51,5	150	M20i	16,5	40°
6001703357	220	180	110	150	51,5	150	M20i	16,5	55°
6001703368	220	180	110	150	51,5	150	M20i	16,5	70°

Indien gewenst is de machinevoet leverbaar met hoogteverstelling

- L = lengte
- Ls = hartafstand bevestigingsgaten
- K = diameter kap
- D = diameter
- H = hoogte
- B = breedte
- M = schroefdraad
- d = boring
- Shore A = hardheid

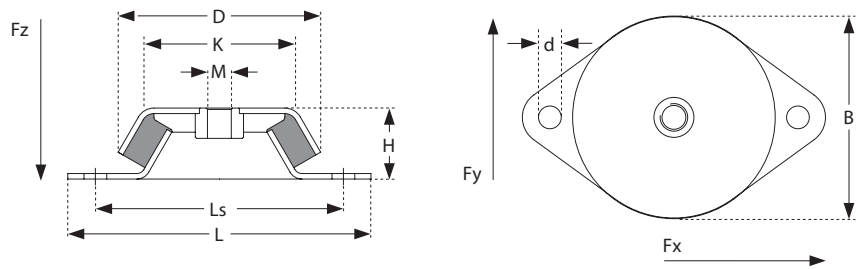

### Belasting Fz

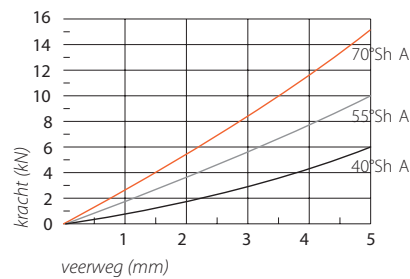

Art.Code	L (mm)	Ls (mm)	K (mm)	D (mm)	H (mm)	B (mm)	M (mm)	d (mm)	Shore A
6002003443	184	150	126	175	63	184	M20i	13	40°
6002003457	184	150	126	175	63	184	M20i	13	55°
6002003468	184	150	126	175	63	184	M20i	13	70°

Indien gewenst is de machinevoet leverbaar met hoogteverstelling

- L = lengte
- Ls = hartafstand bevestigingsgaten
- K = diameter kap
- D = diameter
- H = hoogte
- B = breedte
- M = schroefdraad
- d = boring
- Shore A = hardheid

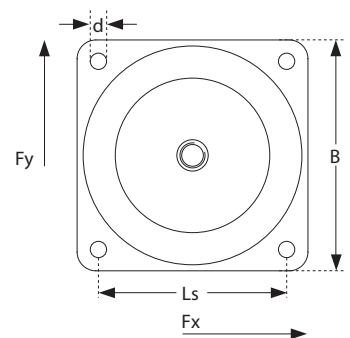
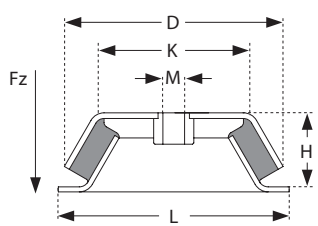

### Belasting Fz

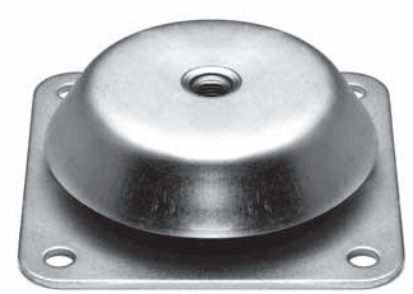
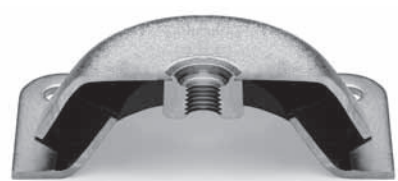
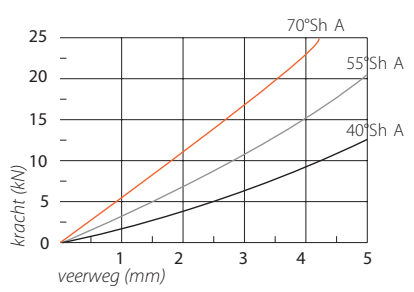

# Doorslagbeveiligde machinevoeten

standaard

Art.Code	L (mm)	Ls (mm)	K (mm)	D (mm)	H (mm)	B (mm)	M (mm)	d (mm)
60060001/03	93	76	50	63	35	63	M12i	9
60060001/04	93	76	50	63	35	63	M12i	9
60060001/05	93	76	50	63	35	63	M12i	9
60060001/06	93	76	50	63	35	63	M12i	9

Indien gewenst is de machinevoet leverbaar met hoogteverstelling

- L = lengte
- Ls = hartafstand bevestigingsgaten
- K = diameter kap
- D = diameter
- H = hoogte
- B = breedte
- M = schroefdraad
- d = boring
- Shore A = hardheid

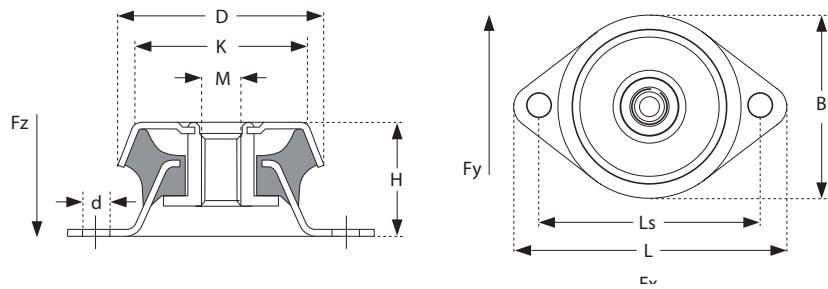

## Belasting Fz

